

	Engineering Standard	Doc Number: ES0001	Revision: -
	Title: Fax/Email Form For Custom Flywheels	Author: SRV	Effective Date: 17/07/2013

FAX: 01473 312014
EMAIL: info@ttvracing.com

Flywheel Design Data

Engine Details:	
Gearbox Details:	
Spline Details:	
Clutch Details:	

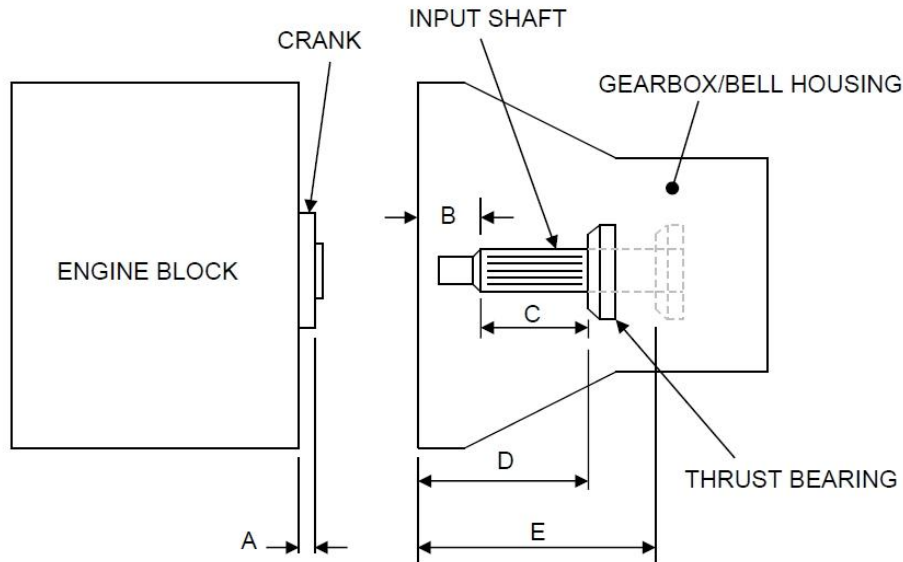

A	Dimension from crank face to block where bell housing mates		mm/inches
B	Dimension from bell housing face to start of splines		mm/inches
C	Length of splines		mm/inches
D	Dimension from bell housing face to thrust bearing fully forward		mm/inches
E	Dimension from bell housing face to thrust bearing fully backwards		mm/inches



Use a straight edge and steel rule or vernier caliper to measure dimensions A,B,C,D and E. Please advise if there are any restrictions within the bell housing which could foul the clutch assembly. It is advisable to supply us with an OEM flywheel that matches the starter motor being used. This is so we can ascertain the correct number of teeth and tooth form (including chamfers).

Starter Motor Pinion Entry	Engine Side Y/N	Bell Housing Side Y/N